

# VESDA OPEN PROTOCOL HLI™

## VHX-0300, VHX-0310



### Open Protocol High Level Interface

The VESDA Open Protocol High Level Interface (HLI) links your VESDAnet<sup>1</sup> with PC software monitoring tools, Building Management Systems (BMSs) and Fire Alarm Control Panels (FACPs), otherwise known as 'host'. There are two models available, depending on whether you require communication between your host and VESDAnet to be master-slave or peer-to-peer.



### VHX-0310 Open Protocol HLI (Master-Slave)

In the master-slave model, the host supervises the communications link between itself and the HLI (slave) by regularly polling the HLI to determine whether there has been a change in the status of a detector on VESDAnet. In response to polling by the host, the HLI generates a single response which is sent back to the host. In this way, no unsolicited messages are sent from the HLI to the host. Depending on the polling strategy adopted, the Master/Slave Open Protocol HLI is able to report any and all fire alarms within a few seconds of a detector going into alarm. Exact performance is dependent on the polling strategy adopted.

### VHX-0300 Open Protocol HLI (Peer-to-Peer)

In the peer-to-peer model, the host polls the HLI for information about devices on VESDAnet, while the HLI sends unsolicited messages to the host. In this way, both the HLI and host are responsible for supervising the communications link between them.

In the peer-to-peer model, the host can request and receive multiple messages from the HLI.

### Information Available Using the Open Protocol HLI

- Detector Type (VLC, VLS, VLP, VLF)
- Support Mimic Mode: VLP/VLC/VLS
- Alarm status (Alert, Action, Fire1 & Fire2)
- Fault Status (System, Zone, Urgent, Power, Network, Flow, Filter)
- Status (Isolated, Normalizing, AutoLearn, Scanning)
- Display info (Alarm thresholds, Location name)
- Display update (Smoke level, Alarm & Fault status)
- Fault details (list of active fault codes)
- Fault strings (ASCII strings to describe each fault code)
- Detector controls (Reset, Isolate, Silence, Test, Scan or Normalize<sup>2</sup>)
- Configuration of Day / Night alarm thresholds<sup>2</sup>

### Features

- Direct access and monitoring of your VESDAnet system
- Seamless data transfer
- Easily configured using Xtralis configuring and monitoring software packages

### Listings / Approvals



VESDA HLIs are recommended for secondary monitoring of fire alarms and other notifications from VESDAnet network. They are also suitable for primary reporting to the fire panel or other primary reporting systems. When used for primary reporting VESDA HLIs need to be integrated and approved / listed with the relevant fire panel or the primary reporting system for the relevant fire standards and codes.

<sup>1</sup> VESDAnet is a propriety communications protocol allowing your VESDA range of smoke detectors, displays, programmers and remote units (collectively known as devices) to communicate with each other on the one network. VESDAnet is a fault tolerant bi-directional protocol. This means that if one direction of communication fails, then your VESDAnet messages are transmitted in the opposite direction.

<sup>2</sup> Master - Slave only

# VESDA OPEN PROTOCOL HLI™

## TECHNICAL SPECIFICATIONS



### Dimensions

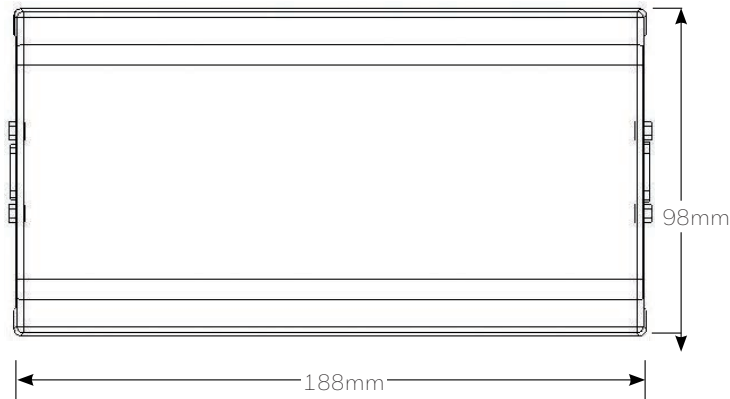

### Ordering Information

Ordering Code	Description
VHX-0300	Open Protocol HLI (Peer-to-Peer)
VHX-0310	Open Protocol HLI (Master-Slave)
VSP-509	VESDALink RS-232 9-way serial cable (Spare part)
VSP-511	VESDAnet RS-485 15-way cable (Spare part)

### Example VESDAnet System With Open Protocol HLI

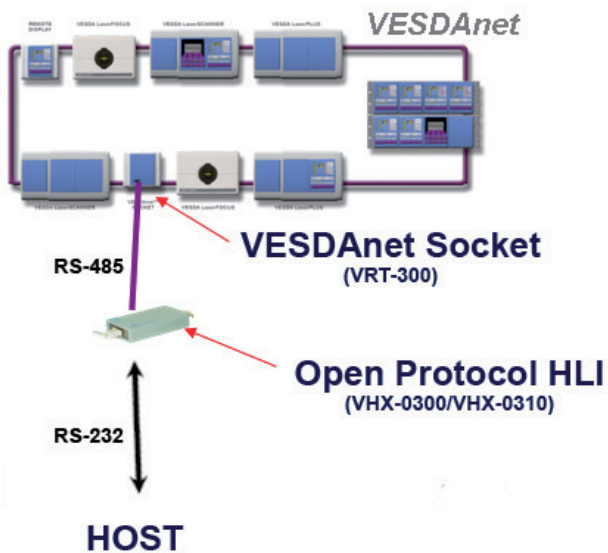

### Specifications

Power Consumption	1.68 W (Quiescent)
Supply Voltage	24 VDC
Current Consumption	70 mA (Quiescent)
Dimensions	188 mm x 98 mm x 40 mm (7.4 in. x 3.9 in. x 1.6 in. approx.)
Weight	0.4 kg (0.9 lbs)
Supplied With	VESDALink RS-232 9-way serial cable (male-female) VESDAnet RS-485 15-way cable (male-female)
Number of Detectors Supported	Up to 40 detectors*
Modem Support	Modem support is not available

\* If your network has more than 40 detectors, please contact your Xtralis representative.